

# Pendant

## INSTRUCTION MANUAL

### Safety Warnings

- This product is only suitable for connection to a 220-240V~ 50Hz supply in accordance with current IEE wiring regulations, and should be installed in accordance with local building regulations. It is for indoor use only, and is **not** suitable for a bathroom location.
- Before installing your light fitting always switch off the mains supply, and remove the appropriate fuse or switch off the appropriate circuit breaker before commencing installation. Ensure that no one else has access that would enable the supply to be inadvertently reconnected.
- **This is a Class II, Double Insulated**  **product and must not be earthed.** The terminal blocks are supplied according to requirements of the fitting.
- This product contains non-replaceable LEDs. If the LEDs become damaged, they cannot be replaced, and the product must be replaced.
- This product may contain delicate parts – be careful during handling and maintenance to avoid breakage.
- If you are in any doubt about your competence please consult a qualified electrician.
- If any modification is made it will invalidate the warranty and may render the product unsafe
- This product is dimmable when used with a suitable LED dimmer switch.

### Care Information

Allow 10 minutes to cool before replacing, adjusting or cleaning.

Clean with a dry cloth only. Do not use liquid or abrasive cleaners on this product.

### Assembly/ User Instructions

#### Before you start

Please read these instructions carefully before fitting and retain for reference. Check the packaging and make sure that you have all the required parts. Follow each assembly step in order to prevent incorrect assembly. Ensure that the product is fully assembled as illustrated before use.

**This instruction manual covers several versions of this fitting.**

#### The Light pack contains:

Light fitting  
Fixing pack

#### The following tools may be required:

Selection of cross and flat head screwdrivers.  
Electric drill and assorted drill bits.  
Wire strippers.

**These assembly diagrams are intended as a guide – if in doubt consult a qualified electrician.**

1. Decide on the position of the light fitting, or remove existing light fitting. Take a note of the position of the electrical connections. Ensure there is a solid mounting surface, preferably a wooden joist or joist bridge to support the weight of the light fitting.
2. Remove the fixing bracket (A) from the ceiling cover by removing the side screws (B).
3. Attach to the ceiling using the screws provided. Ensure there is a joist at the point of fixing to support the weight of the product. Take care to avoid damaging any concealed wiring and pipes.
4. Set the drop height of the product. This will be easier to complete before attaching the product to the ceiling. To reduce the drop of this pendant, push the steel cable up into the ceiling cover. To increase the drop press button D. To reduce the length of the electrical flex, pull the flex through the cable grip E in the ceiling cover. Always ensure the weight of the product is supported by the steel cable and not the electrical flex.
5. Support your fitting and connect the house wiring to the terminal block – see expanded wiring details below. **NOTE: This is a Class II fitting and must NOT be earthed.** Ensure no loose strands are left out of the connection block.

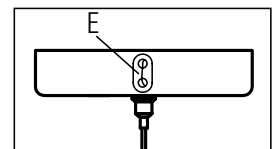
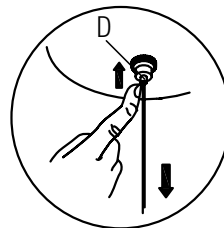

## Assembly/ User Instructions

- This product has “L” shaped fixing slots to allow easy fixing to the ceiling strap. Locate the “L” slots (C) around the small screws (B) on the ceiling strap (A). Rotate the ceiling cover to attach the product to the strap. Tighten the screws to secure. Take care not to trap any wiring.
- Turn on the power and test.

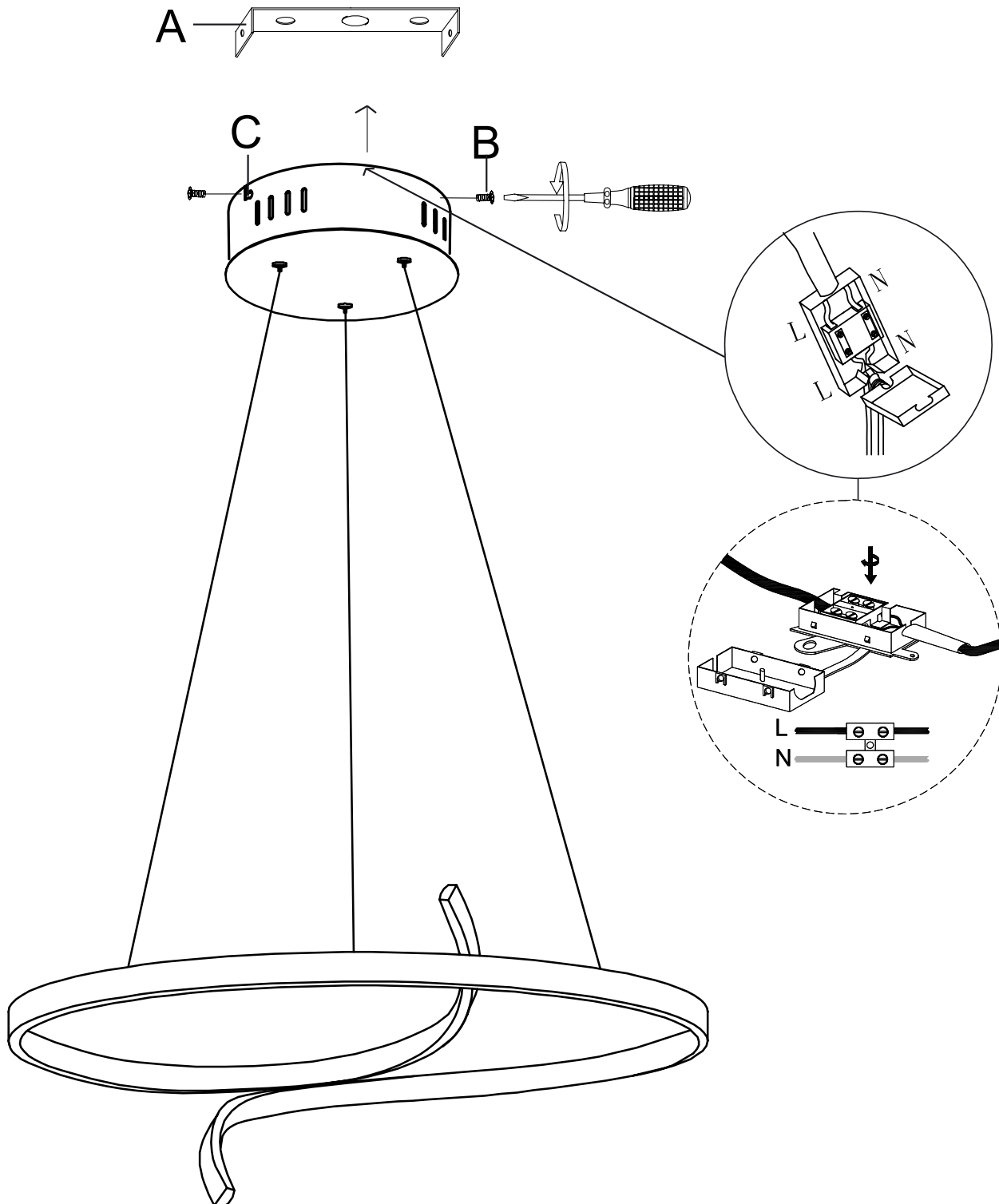

- EN Scan QR code for multi-language
- FR Scannez le code QR pour plusieurs langues
- ES Escanee el código QR para varios idiomas
- PL Zeskanuj kod QR dla wielu języków
- DE Scannen Sie den QR-Code nach mehreren Sprachen
- IT Scansiona il codice QR per multilingua



UK Manufacturer: BH17 7BY  
EU Manufacturer: Brilliant AG,  
Brillantstrasse 1, D-27442 Gnarrenburg